

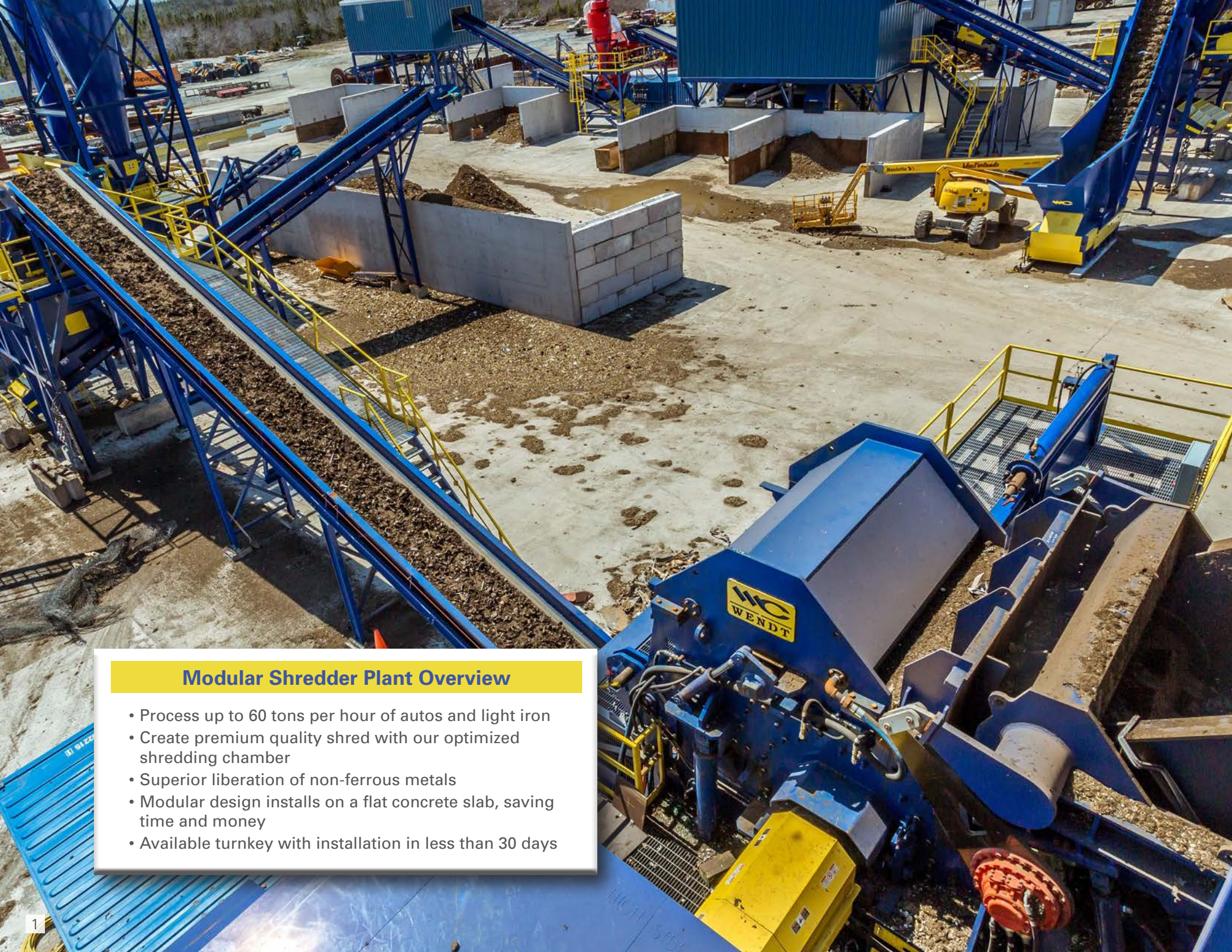

ADVANCED TECHNOLOGY. PROVEN PERFORMANCE.



MODULAR SHREDDERS



Modular Shredder Plant Overview

- Process up to 60 tons per hour of autos and light iron
- Create premium quality shred with our optimized shredding chamber
- Superior liberation of non-ferrous metals
- Modular design installs on a flat concrete slab, saving time and money
- Available turnkey with installation in less than 30 days



Multi-Functional Shredders

Our modular shredder line has a uniquely-engineered multi-functional design that is ideal for shredding automobiles, light iron, various grades of aluminum bales, breakage and more. Processing up to 8,000 tons per month on a single shift, our modular shredders can be combined with our advanced and flexible downstream separation systems.



Shredded Aluminum



Ferrous Scrap



M6090 Shredding Plant

- 1 Infeed Conveyor (Optional)
- 2 E-House
- 3 Fluid Power House
- 4 Control Pulpit (Optional)
- 5 Model M6090 Shredder
- 6 Poker Picker
- 7 Ferrous Cleaning Station – Magnetic
- 8 Ferrous Ballistic Separator
- 9 Picking Station
- 10 Radial Stacker

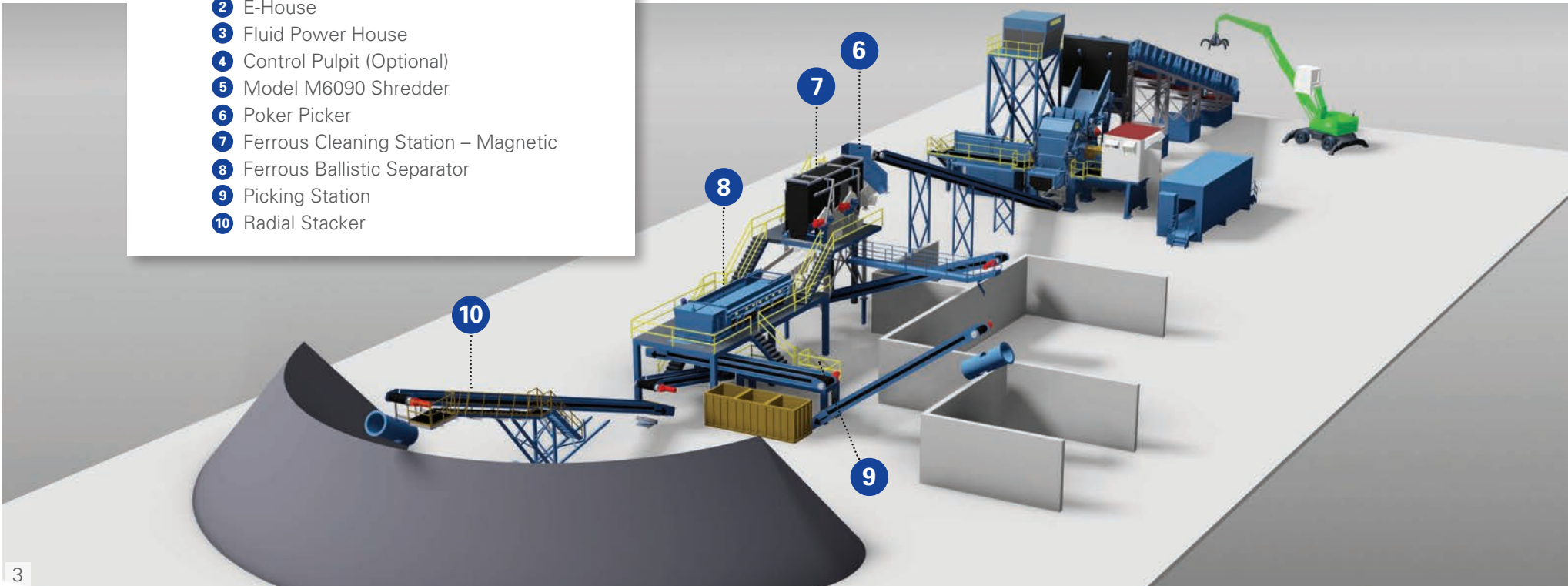

M6060 Compact Shredder

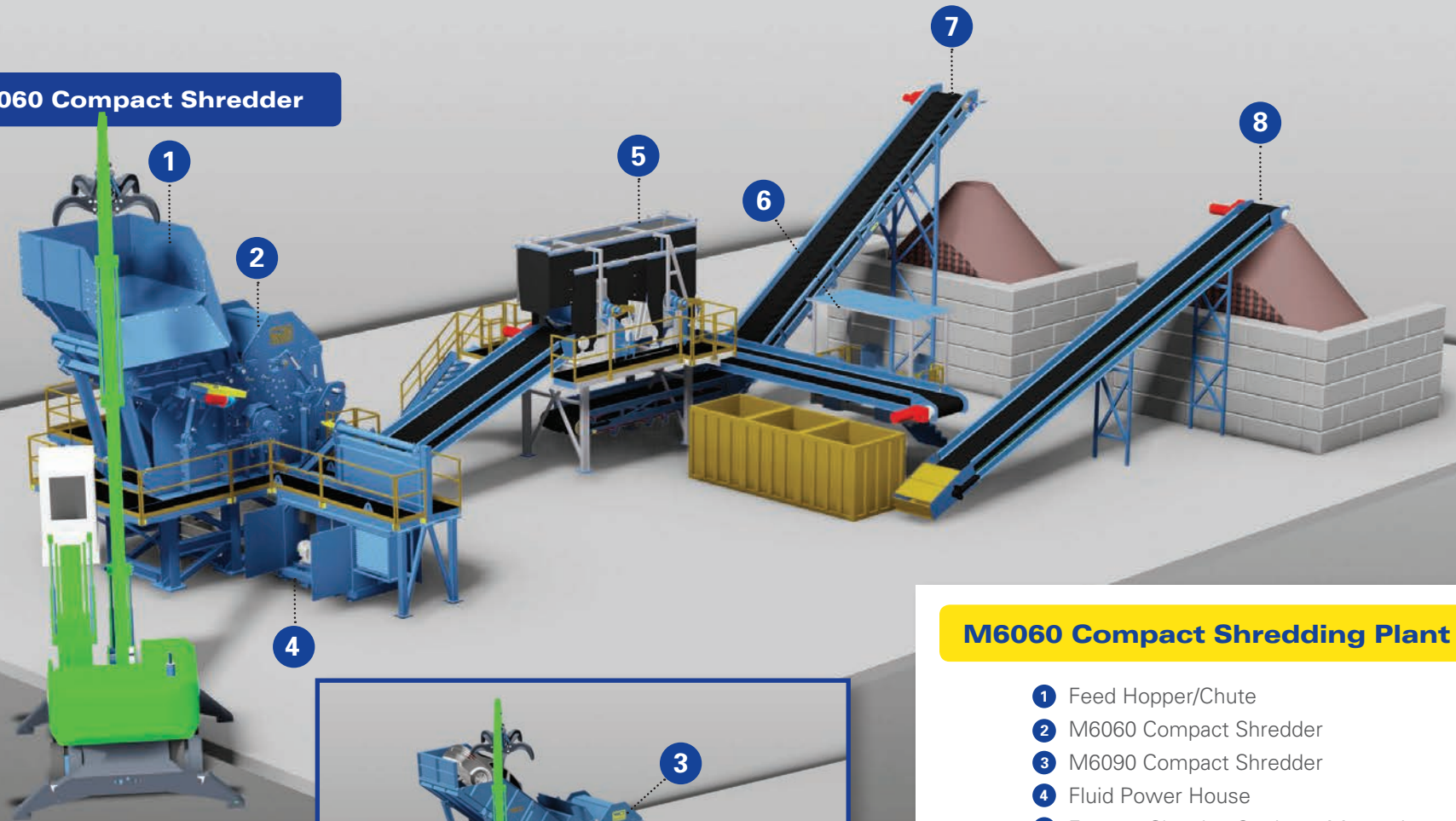

M6060 Compact Shredding Plant

- 1 Feed Hopper/Chute
- 2 M6060 Compact Shredder
- 3 M6090 Compact Shredder
- 4 Fluid Power House
- 5 Ferrous Cleaning Station – Magnetic
- 6 Picking Platform
- 7 ASR Conveyor
- 8 Ferrous Stacking Conveyor

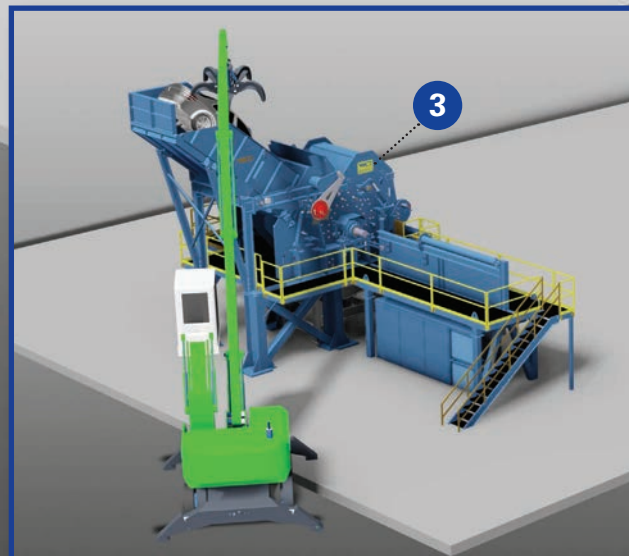

Optional M6090 Compact Shredder

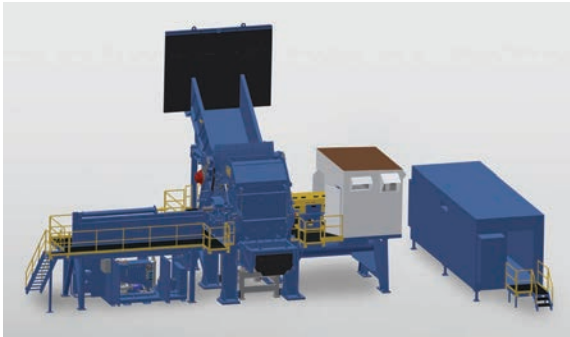

Modular Design Features

The modular design features of this shredder line allow for significantly lower total project costs compared to a “traditional style” shredder installation. These design features allow for the shredder to be installed on a flat concrete pad and eliminate the need for a shredder building which would typically support the pulpit, and contain the motor, hydraulic power units, and electrical rooms. In addition to the reduction of the physical infrastructure, this design greatly reduces the overall installation time and the costs associated with concrete hydraulic and electrical contractors.



Pre-Fabricated Steel Support Structure

The pre-fabricated steel base supports the shredder, motor and pin-puller and installs on a flat concrete pad. The structural steel supports eliminate the need for permanent custom-designed concrete piers, resulting in faster and less expensive site preparation and installation costs.

Pre-Fabricated Motor Building

A pre-fabricated motor building mounts on our structural frame, which provides protection for the motor from outside elements and includes filtered ducting for motor cooling.



Electrical House

Electrical components for the shredder and ferrous downstream come fully installed with Motor Control and PLC Panels in the portable enclosure. The finished interior of the E-House is factory wired and tested with motor starters and control equipment. Heavy beam supports elevate the remote E-House off the ground for ease of field wiring.



Fluid Power House

The pre-fabricated Fluid Power House contains hydraulic production and maintenance systems and arrives on-site pre-piped, pre-wired and completely tested. This turnkey hydraulic enclosure is located under the pin-puller platform and designed to greatly reduce setup time and installation costs.

WENDT Modular Shredder Options



M6060 Compact



M6090 Compact



M6090

Standard Shredder Drive Packages	1000 DC	1000 DC	2500 DC
Estimated Capacity (T/H Input)	25	30	60
Theoretical Tons/Month – 8 hours x 21 days <small>*All Tonnages are in Net Input Tons (2000 lbs) 90% Efficiency</small>	3780 T/M	4536 T/M	9072 T/M
Typical Feed Stock	Light Iron, White Goods, Aluminum	Light Iron, White Goods, Aluminum, Automobiles	Light Iron, White Goods, Aluminum, Automobiles
Infeed Conveyor	Optional	Optional	CAT D-4 Style / 25 ft Load
Feed Chute Length	10 ft x 10 ft Hopper	17 ft	17 ft
Single Feed Roll Diameter	30 in	30 in	30 in
Feed Roll Drive	Electric - 7.5 HP	(1) Hydraulic CA-140	(2) Hydraulic CA-140
Shredder Box			
Hammer Swing Diameter	63.25 in	62.75 in	62.75 in
Width Inside of Bare Shredder Walls	63.5 in	94 in	94 in
Rotor	DISC	DISC	DISC
Discs: Qty./Thickness	7 Discs / 3.5 in Thick	9 Discs / 4.50 in Thick	9 Discs / 4.50 in Thick
Pin Shafts: Diameter	3-7/8"	3-7/8"	3-7/8"
Hammers: Weight	232 lbs	232 lbs	232 lbs
Pin Protectors: Weight	88 lbs	88 lbs	88 lbs
Rotor Bearings (Tapered)	220 mm	260 mm	260 mm
Ferrous Cleaning Station – Magnetic	(2) 60 x 48 Drums	(2) 60 x 48 Drums	(2) 60 x 60 Drums, Optional Shred 1 or Air System
Area Required (Traditional Installation)	150' L x 85' W	150' L x 85' W	300' L x 120' W



WENDT CORPORATION Headquarters, Buffalo NY

Powerful Partnerships: WENDT has created strategic partnerships with industry-leading technology companies. Meaningful strategic partnerships are the foundation for our success. These relationships allow WENDT to focus our resources on what we do best, and to tap into the resources of what they do best.



With over 10,000 machines in operation in over 80 countries, **TOMRA Sorting Solutions** is leading the resource revolution with transformative technologies and sensor-based systems for optimal material separation and recovery.



MTB is the largest wire and cable processor in Europe, chopping more than 40,000 tons per year of copper and aluminum wire and cable. MTB's experience and know-how as an operator is carried through into their design and manufacturing of robust, purpose-built wire chopping equipment.



Bowe Machine Company is synonymous with automobile shredding, offering shredder rotors for all machines regardless of the original equipment manufacturer.



WENDT M6090 Shredder Installation

Turnkey Project Solutions & Services: At WENDT, equipment is only part of what we offer to a customer. What truly makes WENDT unique as a supplier is the ability to deliver an entire project through our pre/post-sale support, custom integration and project management services. We offer a comprehensive array of services that include many of the most critical elements associated with a project such as:

- Site Assessment & Development
- General Equipment Layout
- Enhanced Training Programs
- 24-Hour Customer Support
- Permitting
- Yard Layout: Traffic/Logistics
- Equipment Installation
- Fully Stocked Parts Department



WENDT Non-Ferrous Recovery System

Non-Ferrous Recovery Systems: WENDT offers a full line of non-ferrous separation systems specifically engineered for superior recovery of non-ferrous metals from automobile shredder residue (ASR). We offer scalable non-ferrous plants that minimize installation costs and can easily be upgraded to capitalize on new opportunities when they arise.



WENDT CORPORATION
2555 Walden Avenue
Buffalo, NY 14225-4737
USA

Toll-Free: 1.888.WENDTCO
Tel: 716.391.1200
Fax: 716.393.3444
Email: sales@wendtcorp.com

